

Description and crystal structure of Yvonite, $\text{Cu}(\text{AsO}_3\text{OH})_2\text{H}_2\text{O}$

HALIL SARP¹ AND RADOVAN ČERNÝ²

¹Département de Minéralogie du Muséum d'Histoire naturelle de Genève, 1, route de Malagnou, CH-1208 Geneva, Switzerland

²Laboratoire de Cristallographie, Université de Genève, 24, quai Ernest-Ansermet, CH-1211 Geneva 4, Switzerland

ABSTRACT

Yvonite, $\text{Cu}(\text{AsO}_3\text{OH})_2\text{H}_2\text{O}$, was found in the Salsigne mine near Carcassonne (Aude, France). It forms aggregates or radiating spherules consisting of individual crystals (maximal size $0.3 \times 0.15 \times 0.06$ mm) of turquoise blue color. They are elongated in c , flattened on (010), and have a perfect cleavage on (100). The mineral is triclinic, $P\bar{1}$, $a = 7.632(3)$, $b = 11.168(3)$, $c = 6.020(3)$ Å, $\alpha = 89.32(3)$, $\beta = 86.55(5)$, $\gamma = 74.43(3)^\circ$, $V = 493.4(3)$ Å³, $Z = 4$, $D_{\text{meas}} = 3.20(2)$ g/cm³, and $D_{\text{calc}} = 3.22(1)$ g/cm³. Mohs hardness 3.5–4. Luster vitreous transparent, streak blue; optically biaxial (-) with $\alpha = 1.615(2)$, $\beta = 1.660(2)$, and $\gamma = 1.700(2)$ at 589 nm; $2 V_{\text{obs}} = 82(2)^\circ$, $2 V_{\text{calc}} = 84(1)^\circ$. Pleochroism weak with $Z = \text{blue}$, $Y = \text{light blue}$, and $X = \text{light blue to colorless}$. Associated minerals: geminite, lindackerite, arsenopyrite, native bismuth, chalcopyrite, and pushcharovskite. The crystal structure was solved by direct methods (MoK α radiation) and refined using 1429 observed unique reflections to $R = 0.069$, $R_w = 0.043$. There are two symmetrically independent distorted $\text{CuO}_5(\text{H}_2\text{O})$ octahedra in the structure. They share edges and form cis $[\text{CuO}_5(\text{H}_2\text{O})]$ chains parallel to [001]. Two symmetrically independent distorted $\text{AsO}_3(\text{OH})$ tetrahedra cross-link these chains to form sheets parallel to (100). Two symmetrically independent H_2O molecules are located between the sheets, which are linked by a network of hydrogen bonds, accounting for the perfect cleavage of yvonite. The mineral is structurally related to geminite, $\text{Cu}(\text{AsO}_3\text{OH})(\text{H}_2\text{O})$, and fluckite, $\text{CaMn}[(\text{AsO}_3\text{OH})(\text{H}_2\text{O})]_2$.

INTRODUCTION

The gold-bearing sulfo-arsenic mine of Salsigne has attracted the attention of many mineralogists and collectors due to the large variety of mineral species found there. This mine is located on the south hillside of the Montagne Noire, 15 km north of Carcassonne in the department of Aude (France). It lies at the center of the gold-bearing district of Salsigne. This district is limited on the west by the granite of Brousses, on the south by Tertiary formations discordant on the Paleozoic, on the east by the north-south Valley of Argendouble, and on the north by the mica schists and gneisses of the axial zone of the Montagne Noire. The deposits and the gold-mineralized zones are found in the schists of Cabardès and in the Paleozoic formations of Minervoies. The genesis of the deposit is still controversial. Bonnemaïson et al. (1986) proposes a volcano-sedimentary origin, and Lepine et al. (1988) an exhalative-sedimentary type. The dominant minerals are arsenopyrite, pyrrotite, and pyrite. Accessory phases are chalcopyrite, galena, bismuth species, and gold. Among the bismuth minerals are native bismuth, bismuthinite, maldonite, cosalite, kobellite, gustavite, and matildite. Galena, sphalerite, magnetite, and löllingite are rare. Recently, Marcoux and Lescuyer (1994) have found gudmuntite, bournonite, emplecite, and tetrahedrite.

The mine is also very rich in late-stage supergene hydrated minerals. The phosphates ludlamite, vivianite,

messelite, and childrenite were reported by Descouens and Baffaly (1985), and the sulfates, melanterite, chalcantinite, siderotile, and halotrichite by Descouens (1986). Recently, based on the work of M.G. Favreau (personal

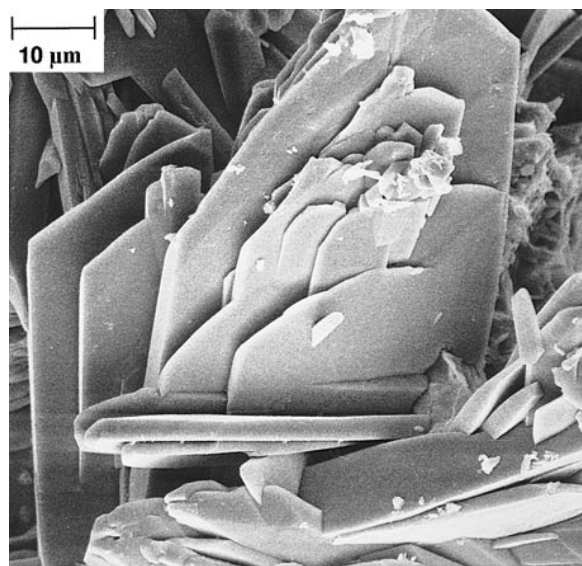

FIGURE 1. Scanning electron microscope photograph of yvonite crystals, elongated in the c axis direction and flattened on (010). Bar scale is 10 μm .

TABLE 1. Optical and physical properties of yvonite

Biaxial, negative	(all data for wavelength of 589 nm)
$\alpha = 1.615(2)$	$2V_{\text{obs}} = 82(2)^\circ$ (universal stage)
$\beta = 1.660(2)$	$2V_{\text{calc}} = 84(1)^\circ$
$\gamma = 1.700(2)$	Pleochroism: weak
Dispersion: $r > v$ medium	Z = blue, Y = light blue, X = light blue to colorless
$\Delta = 0.085$	Absorption: $Z > Y > X$
Orientation:	
on (010): $X \wedge c = 42^\circ$ and Z normal to (010)	
on (100): $Z' \wedge$ normal to [001] = $0-2.5^\circ$ and $X' \wedge c = 3-5.5^\circ$	
Color: turquoise blue	Streak: blue
Luster: vitreous transparent	Tenacity: brittle
Hardness: $\sim 3.5-4$	Fracture: irregular
Cleavage: perfect on {100}	Twinning: very rarely multiple lamellae, composition plane (010), twin axis \perp (010)
poor on {010}	
$D_{\text{meas}}: 3.20(2) \text{ g/cm}^3$ (heavy liquids)	Non-fluorescent under LW and SW
$D_{\text{calc}}: 3.22(1) \text{ g/cm}^3$	Soluble rapidly in HCl

communication), an eminent mineral collector, the number of the supergene secondary minerals has increased. In fact, Favreau collected samples from the dump and from the mine and has recognized the presence of hydrated arsenates such as pharmacosiderite, picropharmacolite, raenthalite, scorodite, sainfeldite, lavendulane, hoernesite, mimetite, olivenite, clinoclase, and pharmacolite and of sulfates such as jarosite, beudantite, chalcophylite, brochantite, posnjackite, serpierite, and siderotil. We have found in one sample supplied by M.G.

Favreau from the dump, a new mineral, which we have named yvonite in honor of Klaus Yvon, professor of crystallography at the University of Geneva, Switzerland. The new mineral and the name have been approved by the Commission on New Minerals and Mineral Names of the International Mineralogical Association. The holotype material is deposited in the department of mineralogy of the Natural History Museum of Geneva, catalogue no. 450/33.

OPTICAL AND PHYSICAL PROPERTIES

Yvonite occurs as aggregates or radiated spherules of maximum size 1 mm in diameter, which are formed by individual crystals of maximum size $0.3 \times 0.15 \times 0.06$ mm. The megascopic color is turquoise blue. The crystals are elongated parallel to c , flattened on (010), and have one perfect {100} cleavage and imperfect {010} cleavage. The most prominent forms are {010} and {100} (see Fig. 1) with some very small crystals also exhibiting {hkl} and {001} forms. The small size of these crystals and the poor quality of the reflections observed by the optical goniometry preclude identification of the {hkl} forms.

Yvonite is transparent and shows a weak pleochroism with thicker fragments. The optical and physical properties are summarized in Table 1 with the optical orientation in Figure 2.

TABLE 2. Chemical analysis [wt%] of yvonite

	Range of 8 analyses	Average of 8 analyses	Calculated from the crystal structure
CuO	32.6–34.3	33.3	33.20
As ₂ O ₅	45.4–49.4	47.8	48.01
Al ₂ O ₃	0–0.8	0.4	—
H ₂ O*	19.0	19.0	18.79
Total		100.5	100.00

* Loss upon heating.

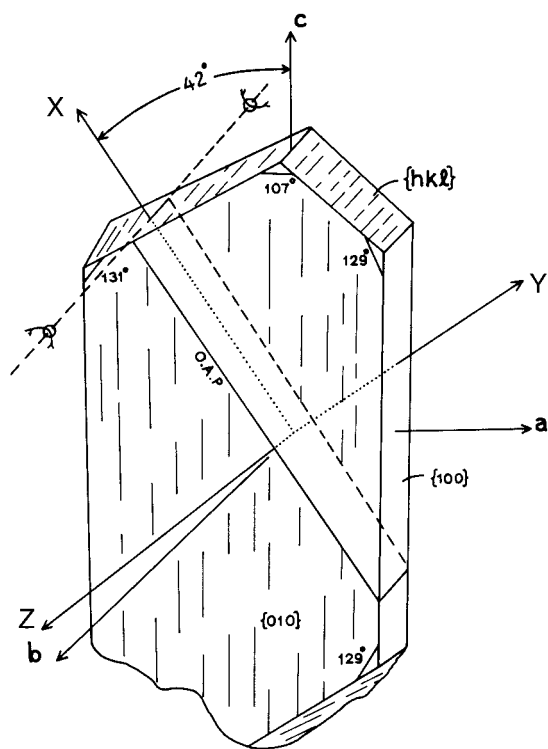

FIGURE 2. Optical orientation of yvonite. Angles between edges were measured with the polarizing microscope.

TABLE 3. Powder diffraction data of yvonite (Guinier-Hägg camera, $\text{CuK}\alpha_1$)

hkl	d_{calc}	d_{obs}	l_{obs}
1 0 0	7.339	7.35	100
0 0 1	6.009	6.014	<5
0 2 0	5.379	5.380	<5
0 1 1	5.236	5.239	50
1 2 0	5.029	5.028	<5
1 1 1	4.685	4.694	5
$\bar{1}$ 1 1	4.443	4.440	60
1 $\bar{1}$ 1	4.121	4.125	5
0 $\bar{2}$ 1	4.017	4.017	5
$\bar{1}$ 1 1	3.937	}3.936	60
1 $\bar{2}$ 1	3.928		
1 2 0	3.872	3.871	<5
2 1 0	3.798	}3.797	<5
$\bar{1}$ $\bar{2}$ 1	3.789		
2 0 0	3.670	3.667	<5
1 3 0	3.629	3.632	<5
0 3 0	3.586	3.592	5
2 $\bar{2}$ 0	3.500	3.503	<5
1 $\bar{2}$ 1	3.307	}3.302	40
$\bar{2}$ 1 1	3.301		
1 $\bar{2}$ 1	3.205	3.201	10
2 1 1	3.127	3.131	15
0 3 1	3.073	}3.072	15
$\bar{1}$ $\bar{3}$ 1	3.073		
0 0 2	3.005	3.008	50
2 $\bar{2}$ 1	2.956	2.957	<5
1 $\bar{3}$ 0	2.927	2.928	10
0 $\bar{1}$ 2	2.897	}2.890	10
0 1 2	2.890		
1 0 2	2.840	2.840	35
1 4 0	2.777	}2.777	5
$\bar{2}$ 1 1	2.777		
2 $\bar{3}$ 1	2.732	2.731	5
1 1 2	2.709	}2.697	<5
0 4 0	2.690		
1 1 2	2.681	2.684	10
1 $\bar{3}$ 1	2.660	2.663	5
0 2 2	2.628	}2.626	<5
1 2 2	2.622		
0 2 2	2.618	2.614	<5
1 1 2	2.578	2.575	5
1 4 1	2.538	2.540	5
2 2 1	2.515	}2.513	10
2 4 0	2.515		
1 4 1	2.504	2.503	<5
0 4 1	2.459	}2.454	5
0 4 1	2.451		
3 0 0	2.446	2.449	<5
2 $\bar{2}$ 1	2.430	2.432	<5
1 2 2	2.414	2.415	<5
2 0 2	2.395	}2.393	5
3 1 1	2.390		
2 4 1	2.350	2.349	10
2 2 2	2.343		
$\bar{1}$ 2 2	2.335	}2.342	5
3 3 0	2.333		
$\bar{1}$ 4 0	2.331	}2.330	5
0 3 2	2.298		
2 1 2	2.291	}2.294	5
2 4 1	2.290		

TABLE 3—Continued.

hkl	d_{calc}	d_{obs}	l_{obs}
2 $\bar{3}$ 0	2.278	2.276	5
2 0 2	2.260	2.262	<5
3 2 1	2.257	2.254	5
3 3 1	2.215	2.213	5
1 4 1	2.190	2.190	5
2 3 1	2.158	2.154	<5
2 1 2	2.140	}2.141	5
$\bar{3}$ 3 1	2.137		
2 3 1	2.102	}2.101	5
1 5 1	2.102		
1 $\bar{5}$ 1	2.084	2.086	5
2 3 2	2.076	}2.075	5
$\bar{3}$ 1 1	2.076		
3 4 1	2.024	}2.024	<5
0 5 1	2.023		
0 4 2	2.008	2.010	<5
2 5 1	1.981	1.982	<5
0 1 3	1.968		
3 4 1	1.965	}1.964	15
2 4 2	1.964		
2 4 0	1.936	1.934	<5
1 1 3	1.899	}1.896	10
4 1 0	1.895		
3 3 2	1.893	1.891	5
3 5 0	1.886	}1.884	<5
$\bar{3}$ 1 2	1.883		
0 2 3	1.874	1.873	<5
1 4 2	1.862	1.861	<5
2 3 2	1.851	1.850	<5
3 0 2	1.844	1.843	5
4 0 0	1.835	1.834	10
2 4 1	1.824	1.822	5
4 3 1	1.794	}1.793	5
0 6 0	1.793		

CHEMICAL COMPOSITION

Yvonite was analyzed with a Cameca electron microprobe, using operating voltage of 5 kV, beam current of 6.8 nA, and a beam diameter of 15 μm . The following standards were used: chalcopyrite ($\text{CuL}\alpha$), arsenic metal ($\text{AsL}\alpha$), and corundum ($\text{AlK}\alpha$). The results of eight analyses performed on five crystals and the average are given in Table 2. The H_2O content was obtained by the weight loss measured by thermal gravimetric analysis (Mettler TA1). The empirical formula based on six O atoms is: $\text{Cu}_{0.99}\text{Al}_{0.02}\text{H}_{0.93}(\text{AsO}_4)_{0.99}\cdot 2.04\text{H}_2\text{O}$ and the ideal simplified formula, $\text{Cu}(\text{AsO}_3\text{OH})2\text{H}_2\text{O}$, was confirmed by structure determination.

The Gladstone-Dale constants of Mandarino (1981) along with the oxide proportions, determined from the electron microprobe data and from the crystal structure, lead to Kc values of 0.200 and 0.198, respectively. The value of Kp (Mandarino 1981), calculated using the average index of refraction (1.658) and the calculated density from the empirical formula, is 0.205. For the same average index of refraction and the calculated density from the idealized formula, Kp is 0.204. The compatibil-

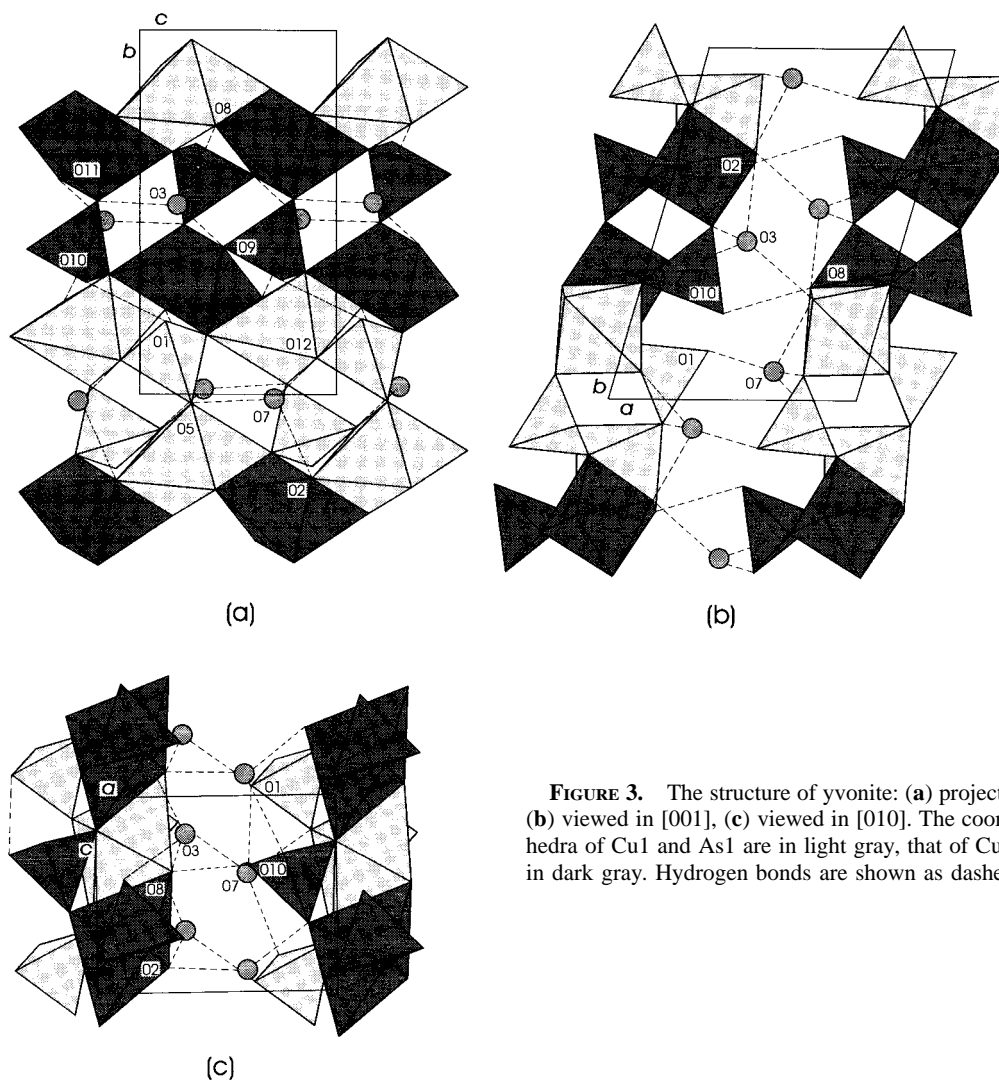

FIGURE 3. The structure of yvonite: (a) projected onto (100), (b) viewed in [001], (c) viewed in [010]. The coordination polyhedra of Cu1 and As1 are in light gray, that of Cu2 and As2 are in dark gray. Hydrogen bonds are shown as dashed lines.

ity index is 0.025 for the empirical formula and 0.030 for the idealized formula, indicating excellent compatibility (Mandarino 1981) between the physical and chemical data.

X-RAY CRYSTALLOGRAPHY

Powder diffraction data for yvonite were obtained using both Gandolfi (114.6 mm diameter, Ni-filtered $\text{CuK}\alpha$) and Guinier-Hägg ($\text{CuK}\alpha_1$) cameras. The Guinier-Hägg data, indexed by program ITO (Visser 1969) and reported in Table 3, led to the conclusion that this mineral is a new species because the results were not consistent with any known mineral species.

Details of the single crystal X-ray data collection and structure refinement of yvonite are given in Table 4. The crystal was first checked by the precession method (Ni-filtered $\text{CuK}\alpha$) and the same crystal was measured on a four circle diffractometer. Data reduction and structure refinement were done by the Xtal3.2 package (Hall et al.

1992). The structure was solved by direct methods with the program SIR92 (Altomare et al. 1994). All non-H atoms were found. Atomic coordinates, standardized by the program Structure Tidy (Gelato and Parthé 1987), and anisotropic displacement parameters for non-H atoms are given in Table 5; a list of interatomic distances in As and Cu coordination polyhedra is given in Table 6.

DESCRIPTION OF THE STRUCTURE

Yvonite contains two symmetrically independent distorted $\text{Cu}\phi_6$ octahedra (where ϕ is an unspecified ligand) and two symmetrically independent distorted $\text{As}\phi_4$ tetrahedra in the structure. It consists of infinite cis $[\text{Cu}\phi_4]$ chains parallel to c formed from $\text{Cu}\phi_6$ octahedra, which share edges O2-O4 and O6-O8 (Fig. 3a). Two chains related by the inversion center are linked along b by sharing vertices with the $\text{As}\phi_4$ tetrahedra. The resulting sheet of

TABLE 4. Crystal data and details of the X-ray data collection and refinement for yvonite

Cu[H ₂ O HOAsO ₃]-H ₂ O	Irregular fragment
$M_r = 239.5$	$0.056 \times 0.032 \times 0.016$ mm
Triclinic	$P\bar{1}$
$a = 7.632(3)$ Å $\alpha = 89.32(3)^\circ$	$V = 493.4(3)$ Å ³
$b = 11.168(3)$ Å $\beta = 86.55(5)^\circ$	$Z = 4$
$c = 6.020(3)$ Å $\gamma = 74.43(3)^\circ$	$\mu = 11.03$ mm ⁻¹
Cell parameters from 34 reflections, $2\theta = 11\text{--}58^\circ$, program Stoe DIF4 (Stoe and Cie 1988)	MoK α radiation, graphite monochromator, $\lambda = 0.71073$
Philips PW1100 diffractometer	$\theta/2\theta$ scanning mode; $2\theta_{\max} = 60^\circ$
Measured reflections: 6242	$-10 < h < 10$
Unique reflections: 2870	$-15 < k < 15$
Absorption correction: analytical from measured crystal shape and size according to Blanc et al. (1991)	$-8 < l < 8$
Refinement on F	Weighting scheme: $1/\sigma^2$
Observed reflections: 1429	$F_{\text{obs}} > 4 \sigma(F_{\text{obs}})$
Extinction correction: Becker and Coppens (1974)	Extinction parameter $g = 0.13(8)$
$R = 0.069$	Parameters: 146
$R_w = 0.043$	Residua in ΔF map: $-2.06, 2.72$ e/Å ³
GoF = 1.48	

polyhedra is parallel to (100), and the O3 and O7 atoms, which are not directly bounded to any cation, are located between the sheets (Figs. 3b and 3c).

Because no H atoms could be found in the ΔF map due to insufficient resolution of the measured X-ray data, the concept of bond valences (Brown and Wu 1976) was used to propose the possible hydrogen bonds. The data of Brese and O'Keefe (1991) were used to calculate the bond valences (excluding H) for all non-H atoms (see Table 7). The O3 and O7 valence sums are 0, thus these sites represent H₂O molecules not included in the coordination of cations. The sums for O2 (0.51) and O8 (0.45) suggest they probably represent H₂O molecules, and likewise the sums for O1 (1.13) and O10 (0.96) suggest they probably represent OH groups. The sums for all other O atoms range from 1.76 to 1.92, thus indicating that some of them form H $\cdot\cdot$ O bridges. Valence sums for both Cu and both As atoms are in good agreement with their cor-

responding ionic charge, and their coordination polyhedra are CuO₅(H₂O) and AsO₃(OH).

Based on the dependence of H $\cdot\cdot$ O bond valence on O $\cdot\cdot$ O distance according to Brown and Altermatt (1985) we have proposed possible hydrogen bonds (assuming normal O-H $\cdot\cdot$ O bond angles). The results are given in Table 7. The H₂O molecules O3 and O7 contribute by their hydrogen bonds to the bonding between two [CuO₃(H₂O)] chains in the same sheet. The H₂O molecules O2 and O8 form with their H atoms one intralayer and one interlayer bond each. The OH group O1 forms an interlayer hydrogen bond and OH group O10 forms an intralayer hydrogen bond. The (100) cleavage is consistent with the direction of weakly bonded sheets.

DISCUSSION OF THE STRUCTURE

Both CuO₅(H₂O) octahedra show a strong distortion associated with Jahn-Teller instability (Jahn and Teller

TABLE 5. Atomic positions and displacement parameters (Å²) for yvonite (except hydrogen)

Atom	x/a	y/b	z/c	U_{eq}	U_{11}	U_{22}	U_{33}	U_{12}	U_{13}	U_{23}
Cu1	0.1141(3)	0.8034(2)	0.2145(3)	0.0127(7)	0.012(1)	0.008(1)	0.018(1)	-0.0031(8)	0.006(1)	0.0038(9)
Cu2	0.0865(3)	0.6631(2)	0.7243(3)	0.0126(7)	0.013(1)	0.009(1)	0.015(1)	-0.0010(8)	-0.005(1)	-0.0002(9)
As1	0.1663(2)	0.0730(1)	0.1464(3)	0.0098(6)	0.0091(9)	0.0070(8)	0.013(1)	-0.0010(7)	-0.0014(8)	0.0028(7)
As2	0.1579(2)	0.3676(1)	0.6752(3)	0.0091(6)	0.0075(9)	0.0065(8)	0.013(1)	-0.0005(7)	-0.0014(8)	-0.0001(7)
O1 (OH)	0.348(1)	0.1377(9)	0.102(2)	0.011(4)	0.013(6)	0.011(5)	0.012(6)	-0.005(4)	0.002(5)	0.000(5)
O2 (W)	0.709(1)	0.2870(8)	0.147(2)	0.009(3)	0.012(5)	0.011(5)	0.005(6)	-0.002(4)	0.003(5)	-0.002(4)
O3 (W)	0.375(1)	0.4519(8)	0.159(2)	0.013(4)	0.013(6)	0.010(5)	0.014(6)	-0.002(4)	0.002(5)	-0.001(5)
O4	0.003(1)	0.6686(8)	0.161(2)	0.012(4)	0.010(6)	0.011(5)	0.016(6)	-0.005(4)	0.003(5)	-0.001(5)
O5	0.247(1)	0.9271(8)	0.242(2)	0.011(4)	0.010(5)	0.009(5)	0.013(6)	-0.002(4)	0.000(5)	0.001(5)
O6	0.017(1)	0.1608(8)	0.335(2)	0.013(4)	0.011(6)	0.011(5)	0.015(6)	-0.002(4)	0.002(5)	-0.004(5)
O7 (W)	0.633(1)	0.0844(9)	0.346(2)	0.017(4)	0.017(6)	0.019(6)	0.018(7)	-0.006(5)	-0.004(6)	0.003(5)
O8 (W)	0.316(1)	0.6804(9)	0.355(2)	0.016(4)	0.017(6)	0.018(6)	0.013(6)	-0.004(5)	-0.003(5)	0.004(5)
O9	0.113(1)	0.3804(9)	0.404(2)	0.013(4)	0.012(6)	0.016(6)	0.010(6)	-0.003(5)	0.000(5)	-0.002(5)
O10 (OH)	0.362(1)	0.2457(9)	0.690(2)	0.017(4)	0.013(6)	0.016(6)	0.020(7)	0.000(5)	-0.004(6)	0.001(5)
O11	0.219(1)	0.4908(8)	0.766(2)	0.011(3)	0.010(5)	0.012(5)	0.011(6)	-0.004(4)	-0.004(5)	-0.001(5)
O12	0.094(1)	0.0747(9)	0.889(2)	0.016(4)	0.014(6)	0.016(6)	0.016(7)	-0.001(5)	-0.005(5)	0.001(5)

Note: The equivalent isotropic atomic displacement parameters are expressed as $U_{\text{eq}} = (1/3)\sum_i \sum_j U_{ij} a_i^* a_j^* \mathbf{a}_i \cdot \mathbf{a}_j$. Esds are given in parentheses.

TABLE 6. Interatomic distances (Å) in As and Cu coordination polyhedra

Cu1-O12	1.922(9)	O2-O4	2.92(1)
Cu1-O5	1.94(1)	O2-O8	3.05(1)
Cu1-O4	1.95(1)	O2-O5	3.31(1)
Cu1-O8 (W)	1.993(9)	O2-O12	3.53(1)
Cu1-O2 (W)	2.558(9)	O6-O8	3.19(1)
⟨Cu1-O⟩	2.83(1)	O6-O5	3.45(1)
⟨Cu1-O⟩	2.199	O6-O12	3.50(2)
Δ	0.023	O6-O4	3.58(1)
		O4-O8	2.75(1)
		O4-O12	2.78(1)
		O5-O8	2.75(1)
		O5-O12	2.79(1)
Cu2-O9	1.93(1)	O4-O2	2.92(1)
Cu2-O11	1.940(9)	O4-O11	3.19(1)
Cu2-O6	1.950(9)	O4-O9	3.65(1)
Cu2-O2 (W)	1.99(1)	O4-O6	3.51(1)
Cu2-O4	2.66(1)	O8-O2	3.01(1)
Cu2-O8 (W)	2.78(1)	O8-O6	3.19(1)
⟨Cu2-O⟩	2.208	O8-O11	3.41(1)
Δ	0.023	O8-O9	3.73(1)
		O2-O6	2.70(1)
		O2-O11	2.75(1)
		O9-O6	2.79(1)
		O9-O11	2.81(1)
As1-O6	1.679(9)	O1-O12	2.64(1)
As1-O12	1.68(1)	O1-O5	2.77(1)
As1-O5	1.689(9)	O1-O6	2.77(1)
As1-O1 (OH)	1.73(1)	O5-O6	2.77(1)
⟨As1-O⟩	1.695	O5-O12	2.79(1)
		O6-O12	2.84(1)
As2-O4	1.66(1)	O10-O11	2.69(1)
As2-O11	1.67(1)	O10-O9	2.75(1)
As2-O9	1.68(1)	O10-O4	2.79(1)
As2-O10 (OH)	1.777(9)	O4-O11	2.78(1)
⟨As1-O⟩	1.697	O4-O9	2.81(1)
		O9-O11	2.78(1)

Note: Δ is a root-mean-square deviation from the mean distance ($= \Sigma[(l - l_0)/l]^2/6$).

1937). The axial bonds are strongly lengthened. The dependence of mean values of Cu-φ bond length on the bond-length distortion $\Delta = \Sigma [(l - l_0)/l]^2/6$ (Table 6) follow the linear relationship given by Eby and Hawthorne (1993). Both AsO₃OH tetrahedra are acid groups, and the As-OH distance is the longest As-φ distance in each of the tetrahedra (Table 6).

The structure of yvonite, Cu(AsO₃OH)2H₂O, belongs to the group of infinite sheet structures with M = M-T type of sheets according to the classification of Eby and Hawthorne (1993). The ideal octahedral sheet is only half occupied by Cu²⁺ in yvonite, which gives cis [CuO₅(H₂O)] chains parallel to *c*. Opposing each vacant octahedral site is the arsenate group, alternatively from each side of the sheet. The sheets are linked solely by hydrogen bonding involving the (H₂O) groups of the CuO₅(H₂O) octahedra, the (OH) groups of the AsO₃(OH) tetrahedra, and the (H₂O) groups in between the sheets.

The same type of sheets can be found in geminite, Cu(AsO₃OH)(H₂O) (Sarp and Perroud 1990; Cooper and Hawthorne 1995), and fluckite, CaMn[(AsO₃OH)(H₂O)]₂ (Catti et al. 1980). The structure of geminite was described by Cooper and Hawthorne (1995) in the nonstandard space group $C\bar{1}$. It can be transformed to $P\bar{1}$ with a cell of half volume, and the geminite shows isotypy with koritnigite, Zn(AsO₃OH)(H₂O) (Keller et al. 1980); cobaltkoritnigite, (Co,Zn)(AsO₃OH)(H₂O) (Schmetzer et al. 1981); and Co(AsO₃OH)(H₂O) (Zettler et al. 1979). One (100) sheet in the yvonite structure is similar to the (001) sheet in geminite or (010) sheet in fluckite. The structure of geminite comprises two sheets; the structures of yvonite and fluckite feature a single sheet. In all three structures the sheets are linked only by hydrogen bonds; in yvonite there are also two isolated (H₂O) groups that participate in the interlayer hydrogen bonds. The total number of interlayer hydrogen bonds is 3 per 2 formula units in yvonite, 1 pfu in geminite, and 3 pfu in fluckite. Twinning of yvonite crystals was observed very rarely (see Table 1) in contrast to geminite (Sarp and Perroud 1990).

TABLE 7. Bond valences and their sums (Σ) for each atom

	O1 OH	O2 W	O3 W	O4	O5	O6	O7 W	O8 W	O9	O10 OH	O11	O12	Σ
Cu1		0.09		0.46	0.49	0.04		0.40				0.50	1.98
Cu2		0.42		0.07		0.48		0.05	0.45		0.55		2.02
As1	1.13				1.36	1.31						1.35	5.15
As2				1.39					1.41	0.96	1.21		4.97
H1		0.79	0.21										1
H2		0.79					0.21						1
H3			0.79							0.21			1
H4			0.79						0.21				1
H5					0.21		0.79						1
H6							0.79					0.21	1
H7			0.21					0.79					1
H8								0.79		0.21			1
H9	0.79						0.21						1
H10	0.21									0.79			1
Σ excluding H atoms	1.13	0.51	0	1.92	1.85	1.83	0	0.45	1.86	0.96	1.76	1.85	
Σ including H atoms	2.13	2.09	2.00	1.92	2.06	1.83	2.00	2.03	2.07	1.96	1.97	2.06	

Note: The bond valences for H atoms were fixed to 1.

OCCURRENCE AND PARAGENESIS

Yvonite has been identified in two specimens collected from the dumps of the Salsigne mine near Carcassonne in the department of Aude (France). As was mentioned, many supergene secondary hydrated minerals have also been discovered in this mine, such as arsenates, sulfates, and phosphates. These mineral species were found in the samples collected either in the dumps or in the mine. Yvonite is associated with geminite (Sarp and Perroud 1990; Cooper and Hawthorne 1995), lindackerite (Sarp and Dominik 1995), arsenopyrite, native bismuth, chalcopyrite, and with pushcharovskite ($\text{Cu}[\text{AsO}_3\text{OH}]\text{H}_2\text{O}$, new mineral recently approved by I.M.A.; Sarp, unpublished data). Yvonite is therefore a secondary alteration mineral, as are the arsenate minerals that occur with it. It is very difficult to distinguish whether yvonite was formed in-situ in the mine or exterior to it. As it is associated with the geminite, lindackerite, and the pushcharovskite, which all have been discovered at the same place in the Cap Garonne mine, yvonite may also occur in the latter.

ACKNOWLEDGMENTS

We thank J. Wüest for carrying out the scanning electron microscope photographs and J. Bertrand for reviewing the manuscript.

REFERENCES CITED

- Altomare, A., Burla, M.C., Camalli, M., Cascarano, G., Giacovazzo, C., Guagliardi, A., and Polidori, G. (1994) SIR92—A program for automatic solution of crystal structures by direct methods. *Journal of Applied Crystallography*, 27, 435.
- Becker, P.J. and Coppens, P. (1974) Extinction within the limit of validity of the Darwin Transfer Equations. II. Refinement of extinction in spherical crystals of SrF_2 and LiF . *Acta Crystallographica*, A30, 148–153.
- Blanc, E., Schwarzenbach, D., and Flack, H.D. (1991) The evaluation of transmission factors and their first derivatives with respect to crystal shape parameters. *Journal of Applied Crystallography*, 24, 1035–1041.
- Bonnemaison, M., Crouzet, J., Thiercelin, F., and Tollon, F. (1986) Controls on exhalative gold deposits hosted by volcanoclastic sediments in the "schistes x", Salsigne gold district, Montagne-Noire, southern France. *Proceedings of the Gold Symposium, Toronto*, p. 457–469.
- Brese, N.E. and O'Keeffe, M. (1991) Bond valence parameters for solids. *Acta Crystallographica*, B47, 192–197.
- Brown, I.D. and Altermatt, D. (1985) Bond valence parameters obtained from a systematic analysis of the inorganic crystal structure database. *Acta Crystallographica*, B41, 244–247.
- Brown, I.D. and Wu, K.K. (1976) Empirical parameters for calculating cation-oxygen bond valences. *Acta Crystallographica*, B32, 1957–1959.
- Catti, M., Chiari, G., and Ferraris, G. (1980) Fluckite, $\text{CaMn}[\text{HAsO}_4]_2 \cdot 2\text{H}_2\text{O}$, a structure related by pseudo-polytypism to krautite $\text{MnHAsO}_4 \cdot \text{H}_2\text{O}$. *Bulletin de la Société française de minéralogie et de cristallographie*, 103, 129–134.
- Cooper, M.A. and Hawthorne, F.C. (1995) The crystal structure of geminite, $\text{Cu}^{2+}(\text{AsO}_3\text{OH})(\text{H}_2\text{O})$, a heteropolyhedral sheet structure. *Canadian Mineralogist*, 33, 1111–1118.
- Descouens, D. (1986) Minéraux de salsigne. *Monde et Minéraux*, 72, 20–22.
- Descouens, D. and Baffaly, C. (1985) Les phosphates de la mine de salsigne (Aude). *Monde et Minéraux*, 67, 4–5.
- Eby, R.K. and Hawthorne, F.C. (1993) Structural relations in copper oxysalt minerals. I. Structural hierarchy. *Acta Crystallographica*, B49, 28–56.
- Gelato, L.M. and Parthé, E. (1987) Structure Tidy—A computer program to standardize crystal structure data. *Journal of Applied Crystallography*, 20, 139–143.
- Hall, S.R., Flack, H.D., and Stewart, J.M. (1992) Eds. Xtal3.2. Reference manual. Universities of Western Australia, Geneva and Maryland.
- Jahn, H.A. and Teller, E. (1937) Stability of polyatomic molecules in degenerate electronic states. I. Orbital degeneracy. *Proceedings of the Royal Society of London, Series A* 161, 220–235.
- Keller, P., Hess, H., and Riffel, H. (1980) Die Kristallstruktur von Koritnigite, $\text{Zn}[\text{H}_2\text{O}][\text{HOAsO}_3]$. *Neues Jahrbuch für Mineralogie Abhandlungen*, 138, 316–332.
- Lepine, J., Talayssat, M., Crouzet, J., and Tollon, F. (1988) Les minéralisations sulfo-arséniées cambriennes de la mine traditionnelle de Salsigne (Aude, France)—Les gisements métallifères dans leur contexte géologique. *Bureau de Recherche Géologie Minière Document* 158, 627–650.
- Mandarino, J.A. (1981) The gladstone-dale relationship: IV. The compatibility concept and its applications. *Canadian Mineralogist*, 19, 441–450.
- Marcoux, E. and Lescuyer, J.L. (1994) Les minerais sulfo-arséniés aurifères de Salsigne, Aude, France: Evolution paragenétique d'une minéralisation tardi-hercynienne syntectonique en contexte sédimentaire. *Canadian Mineralogist*, 32, 159–177.
- Sarp, H. and Dominik, B. (1995) Redéfinition de la lindackerite: sa formule chimique, ses données cristallographiques et optiques. *Archives Science de Genève*, 48/3, 239–250.
- Sarp, H. and Perroud, P. (1990) La geminite, $\text{Cu}_2\text{As}_2\text{O}_7 \cdot 3\text{H}_2\text{O}$, un nouveau minéral de la mine de Cap Garonne, Var, France. *Schweizerische Mineralogische und Petrographische Mitteilungen*, 70, 309–314.
- Schmetzer, K., Horn, W., and Medenbach, O. (1981) Über kobaltkoritnigite ($\text{Co,Zn}[\text{H}_2\text{O}][\text{AsO}_3\text{OH}]$), ein neues mineral, und pitticit, $\text{Fe}_2\text{O}_3 \cdot \text{As}_2\text{O}_5 \cdot 9-10 \text{H}_2\text{O}$, ein röntgenamorphes Fe-Arsenat-Hydrat. *Neues Jahrbuch für Mineralogie Monatshefte*, H.6, 257–266.
- Stoe and Cie (1988) DIF4. Diffractometer control program. Version 7.0. Darmstadt, Bundes Republic Deutschland.
- Visser, J.W. (1969) A fully automatic program for finding the unit cell from powder data. *Journal of Applied Crystallography*, 2, 89–95.
- Zettler, F., Riffel, H., Hess, H., and Keller, P. (1979) Cobalhydrogenarsenat-monohydrat. Darstellung und kristallstruktur. *Zeitschrift für anorganische und allgemeine Chemie*, 454, 134–144.

MANUSCRIPT RECEIVED FEBRUARY 3, 1997

MANUSCRIPT ACCEPTED OCTOBER 16, 1997