

The Infrared Pleochroism of Lawsonite: The Orientation of the Water and Hydroxide Groups

THEODORE C. LABOTKA, AND GEORGE R. ROSSMAN

Division of Geological and Planetary Sciences¹
California Institute of Technology, Pasadena, California 91109

Abstract

Polarized infrared absorption spectra of thin single crystals of lawsonite, $\text{CaAl}_2(\text{OH})_2\text{Si}_2\text{O}_7 \cdot \text{H}_2\text{O}$, have been measured at room temperature and near 78 K. These data suggest a structural model in which the hydrogen atoms of both OH and H_2O lie in planes parallel to (001). The polarization data demand that the order of the energies of the symmetric and antisymmetric stretch of the crystallographically ordered water in lawsonite be reversed from that of liquid water.

Introduction

Lawsonite, $\text{CaAl}_2(\text{OH})_2\text{Si}_2\text{O}_7 \cdot \text{H}_2\text{O}$, a mineral which forms in high pressure, low temperature metamorphic environments, contains both discrete hydroxide groups and water molecules. Since the positions of the hydrogen ions have not been determined, the present study was undertaken to test the feasibility of using infrared spectroscopic techniques to locate hydrogen atoms within a mineral containing both hydroxide groups and water molecules. While the primary applications of infrared spectroscopy to mineralogy have dealt with mineral identification and the determination of information about composition in a solid solution series (Lyon, 1967; White, 1971; Burns and Law, 1970), information can also be obtained regarding the structural state of minerals and polymerization of the silica units (Rutstein and White, 1971; Lazarev, 1972). Single crystal infrared spectra with polarized light and factor group analysis have been applied to study the orientation of water molecules in gypsum (Haas and Sutherland, 1956). The orientation of the hydroxide groups in micas has been investigated (Vedder, 1964; Rouxhet, 1970; Arkhipenko, 1960) by the study of the infrared pleochroism of the hydroxide stretching frequency, and a series of papers by Zemann, Beran, and co-workers (Beran, 1971a,b; Tillmanns and Zemann, 1965) has dealt with the infrared pleochroism of hydroxide present both as a crystal-

chemical constituent and as a trace impurity in a variety of minerals.

Lawsonite is particularly well suited for the study of O-H bond orientations using the technique of infrared spectroscopy because its crystal structure is known, and large, well-formed crystals are available. While it contains both water and hydroxide, the water is not coordinated to any cation and can be treated theoretically as isolated molecular water.

The unit cell dimensions of lawsonite as first determined by Gossner and Mussgnung (1931) are 8.87 Å, 13.25 Å, and 5.88 Å. The lattice constants of lawsonite from the Kantô Mountainland are 8.75 Å, 13.09 Å, and 5.84 Å (Seki, 1957), and the cell dimensions of synthetic lawsonite given by Pistorius (1961) are 8.787 Å, 13.123 Å, and 5.836 Å. Wickman (1947) determined the crystal structure of lawsonite and described the space group as *C222*. The crystal structure (Fig. 1) was refined by Ruminova and Skipetrova (1959) who placed lawsonite in the space group *Ccmm*. Pabst (1959), Davis and Pabst (1960), Ruminova and Belov (1960), and Pabst (1961) have resolved the discrepancy and confirm the space group to be *Ccmm*.

The designation of the crystallographic axes of lawsonite has not been consistent in the literature; in order to conform to the convention described in Mason and Berry (1968, p. 35), the axes are defined as $a = 8.8$ Å, $b = 13.1$ Å, $c = 5.8$ Å. Thus the longest dimension of the crystal is parallel to the *c* crystallographic axis, and the space group designation should be *Bbmm*.

¹ Contribution No. 2360.

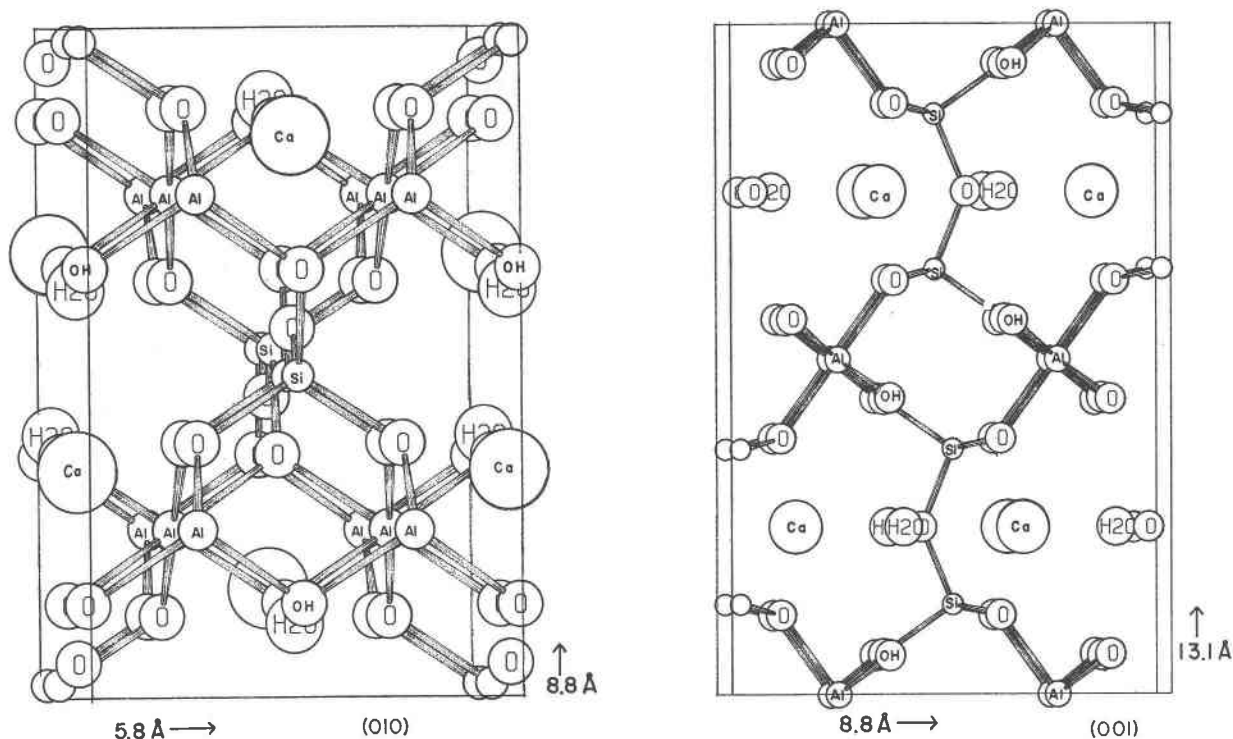

FIG. 1. Projection of the crystal structure of lawsonite on (001) and (010). Atoms are offset in the third dimension for display. Crystal structure data from Ruminova and Skipetrova (1959).

Experimental Methods

The natural lawsonite used in this study originated from Reed Station, Marin County, California. The crystals are approximately 1 cm long, equant to tabular on (010), and display a {101} prism and a {010} pinacoid. The lawsonite is orthorhombic, biaxial positive, $2V\gamma \cong 78^\circ$ with $\alpha = 1.666 = c$, $\beta = 1.672 = a$ and $\gamma = 1.687 = b$. Analytical data, obtained with an automated Mac V electron microprobe on a few samples at selected points, indicate a typical cation formula proportion of $\text{Ca}_{1.02}(\text{Al}_{1.96}\text{Fe}_{0.04})\text{Si}_{1.99}$. The only other element detected was Ti at the 0.00x formula proportion level.

The crystals of lawsonite were hand picked and identified by X-ray powder diffraction. Single, un-twinned crystals were oriented on a primary axis by the back reflection Laue method and ground flat parallel to (001) and (010). The crystals were then ground to approximately $40 \mu\text{m}$ in thickness and both sides of the crystal were polished with $0.3 \mu\text{m}$ alumina to minimize surface scattering of incident light. The orientations of remaining axes within crystal chips were then determined optically.

It was necessary experimentally to determine the

infrared spectrum in two stages. In order to measure the absorption of lawsonite in the 3500 cm^{-1} region, the crystal must be ground to $10 \mu\text{m}$ or less. The many perfect cleavages in lawsonite preclude the accomplishment of this task without permanently mounting lawsonite on a more easily handled material. A synthetic aluminum oxide crystal was chosen, and the lawsonite was mounted on this substrate in a rigid wax. The wax and the Al_2O_3 substrate are almost completely transparent in the range of $4000\text{--}3000 \text{ cm}^{-1}$; however, the wax has two sharp absorption bands at 2905 cm^{-1} and at 2840 cm^{-1} and Al_2O_3 becomes opaque at approximately 2000 cm^{-1} . The bands near 1600 cm^{-1} were first measured on a $40 \mu\text{m}$ self-supporting crystal of lawsonite, and then this crystal was mounted on the Al_2O_3 substrate and ground to $8 \mu\text{m}$ in order to measure the bands around 3500 cm^{-1} . A potassium bromide pellet was also prepared and the infrared spectrum of lawsonite was measured in the region from 4000 cm^{-1} to 300 cm^{-1} . Lawsonite powder mounted in paraffin wax on a polyethylene substrate was used to obtain the far-infrared spectrum in the range $400\text{--}35 \text{ cm}^{-1}$. These measure-

ments were made on a Perkin-Elmer model 180 double beam spectrophotometer equipped with a rotatable gold grid on silver bromide polarizer. The polarization ratio (I_{\parallel}/I_{\perp}) at a wavelength of $3 \mu\text{m}$ is 100, so at 3500 cm^{-1} a small component of unpolarized light is present. The efficiency of the polarizer increases rapidly with increasing wavelength.

Infrared Spectra and Pleochroism

Figure 2 shows the absorption spectrum of lawsonite in the regions from 4000 cm^{-1} to 35 cm^{-1} . The prominent broad absorption bands in the regions $3250\text{--}2700 \text{ cm}^{-1}$ and 1600 cm^{-1} correspond to absorption by H_2O . Also present is a narrower absorption band centered at approximately 3560 cm^{-1} corresponding to the absorption of radiation by the hydroxide anion. The spectrum at lower energy corresponding to the absorption by the aluminosilicate groups is also presented because it differs significantly from that of Moenke (1962). The pleochroism of lawsonite was measured in the region from 4000 cm^{-1} to 1300 cm^{-1} in which the internal vibrational modes of water and hydroxide occur.

Spectra taken with the sample temperature near 78 K help to clarify the features in the OH stretching region by narrowing the bandwidths and increasing the intensity of the bands. Shifts in the positions of the bands also occur, a common phenomena in cryogenic temperature spectra of OH groups which is probably related to changes in the hydrogen

bonding framework with temperature. Two narrow bands at 3618 and 3543 cm^{-1} are now observed in the hydroxide ion band, and the water absorptions are well-resolved into two bands at 3160 and 2778 cm^{-1} (Fig. 3).

The absorption spectrum of lawsonite in the middle infrared region (Fig. 4) was obtained with the infrared radiation plane polarized and the electric vector orientated parallel to the a , b , and c , axes of lawsonite. The general features shown in Figure 2 are better defined. With $E \parallel a$, there is a sharp, well-defined band at 1600 cm^{-1} and absorption maxima at 3560 cm^{-1} and 3250 cm^{-1} . The $E \parallel b$ spectrum does not show the 1600 cm^{-1} peak, but rather two less intense and slightly broader bands at 1550 cm^{-1} and 1695 cm^{-1} . The band at 3560 cm^{-1} is nearly identical to that with $E \parallel a$, but with slightly less intensity. The 3250 cm^{-1} peak with $E \parallel b$ is subdued, but there is a relatively broad band centered at $\sim 3070 \text{ cm}^{-1}$. Finally, the $E \parallel c$ spectrum shows no absorption at 1600 cm^{-1} , no absorption in the 3200 cm^{-1} region, and weak bands centered at 3500 cm^{-1} and 3070 cm^{-1} . The averaging of the features near 1600 cm^{-1} will cause a broad band centered at 1620 cm^{-1} , as seen in Figure 2; similarly the features near 3500 cm^{-1} will average to the broad bands shown in Figure 2.

Polarized spectra at (ca) 85 K in the ab plane are shown in Figure 5. The 3160 cm^{-1} band is clearly polarized in the a direction and the 2778 cm^{-1} band, partly admixed with the wax CH bands,

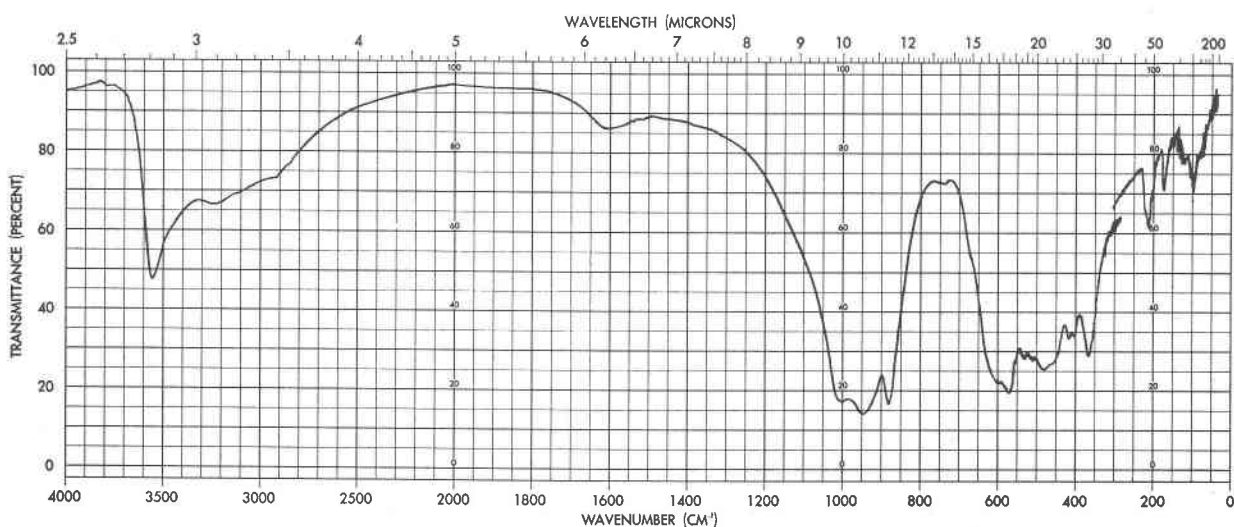

FIG. 2. Infrared spectrum of lawsonite powder in KBr pellet ($4000 \text{ cm}^{-1}\text{--}300 \text{ cm}^{-1}$) and in wax on a polyethylene substrate ($300 \text{ cm}^{-1}\text{--}35 \text{ cm}^{-1}$).

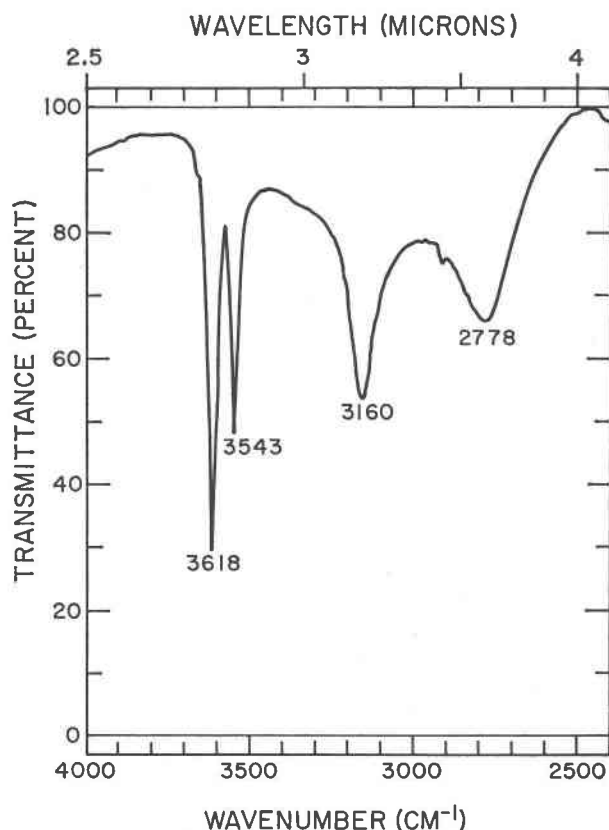

FIG. 3. Infrared spectrum of lawsonite in KBr pellet near 78 K showing improved resolution of water and hydroxide features.

is clearly *b*-polarized. The twin features at 3618 and 3543 cm^{-1} remain unpolarized in this plane.

Pleochroism in the infrared is indeed present and can be interpreted in terms of the orientation of oxygen-hydrogen bonds within the crystal structure of lawsonite.

Assignment of Bands

The stretching motion of the hydroxide ion is characterized by a sharp absorption band in the region of 3700–3500 cm^{-1} , usually at a higher frequency and greater intensity than the OH stretches in water (Nakamoto, 1963). Thus the 3560 cm^{-1} band in lawsonite is assigned to the hydroxyl stretching motion. Water, a molecule with C_{2v} symmetry, has three internal modes of vibration, a symmetric stretch (A_1), an antisymmetric stretch (B_2), and a bending motion (A_1). Each of these modes of vibration of water in the liquid state absorbs at a different frequency, the bending mode at about 1600 cm^{-1} and the two stretching modes in the

region of 3500 to 3200 cm^{-1} (Nakamoto, 1963). The band occurring in lawsonite at 1600 cm^{-1} is assigned to the bending mode of water and those at 3250 cm^{-1} and 3070 cm^{-1} correspond to the OH stretching modes in water (at this point the two are not distinguished). Numerous weak absorptions appear in the various polarizations which represent overtone and combination bands. These features such as the weak bands in the 1500–1700 cm^{-1} region in the *b* polarization will not be further discussed.

Orientation of Hydroxide Groups

Because lawsonite is an orthorhombic crystal, the axes of any three-dimensional figure corresponding to some physical property of lawsonite must coincide with the crystallographic axes. The symmetry of the crystal demands that the three-dimensional figure for the absorption of radiation at an energy of 3560 cm^{-1} by OH also follows this requirement. The measured absorption figure does satisfy the symmetry and is shown in Figure 6. The figure is roughly circular in the (001) section and dumbbell shaped in the (010) section. If the axes of the figure are labelled according to the crystallographic axes with which they coincide, the axial ratio $a:b:c$ is 1.0:0.96:0.24. Figure 6 illustrates the figure for a crystal 10 μm thick.

In order for an isolated hydroxide ion to absorb radiation, a component of the electric vector must project onto the O–H bond axis. The data indicate (Fig. 6) that the OH bond lies parallel to (001) but do not specifically define the orientation of the OH bond with respect to the *a* axis of lawsonite. Assuming that the orientations of hydroxide bonds are related by reflection symmetry, the almost circular *a*–*b* section probably represents two orientations, 90° apart, for the OH bond.

The two peaks which are observed at low temperature are manifestations of splitting of OH absorption due to the reduced symmetry of the site. Site group analysis (see below) indicates that four modes of vibration closely spaced in energy can occur in this frequency region.

Orientation of Water Molecule

Figure 4 shows that the bending mode of water (1600 cm^{-1}) absorbs when the electric vector is parallel to the *a* axis of the crystal. Similarly, one of the stretching modes of water (3250 cm^{-1}) absorbs with the electric vector parallel to the *a* axis

and the other (3070 cm^{-1}) parallel to the b axis. In order for a transition to occur in the infrared, the transition moment, $\langle \Psi | q | \Psi \rangle$, must be non-zero. This integral is non-zero when the integrand is totally symmetric. For the totally symmetric vibrations of free H_2O (the symmetric stretch and the bending mode), the electric vector must be parallel to the two-fold axis of the water molecule in order for the vibration to occur. But for the antisymmetric stretching mode of water, the electric vector must lie in the plane of the molecule, perpendicular to the molecular axis.

Although the water in lawsonite is crystallographically ordered, the crystal structure indicates that the water is neither coordinated nor strongly bound to any cation, but rather the molecule is held in a cage. For this reason, the normal modes of vibration of the water molecule in lawsonite can be treated as those of free H_2O . The data indicate that the

two-fold axis of the molecule is parallel to the a crystallographic axis of lawsonite, that the plane of the molecule lies in the (001) plane, and that the 3250 cm^{-1} absorption band corresponds to the symmetric stretching mode of water.

Note that this model requires that the symmetric stretching mode absorbs at a higher frequency than the antisymmetric mode, contrary to the rule of thumb proposed by Nakamoto (1963). Hornig, White, and Reding (1958) and Haas and Hornig (1960) have found that the order of these absorptions for ice is also reversed.

Starting with this model for the orientation of

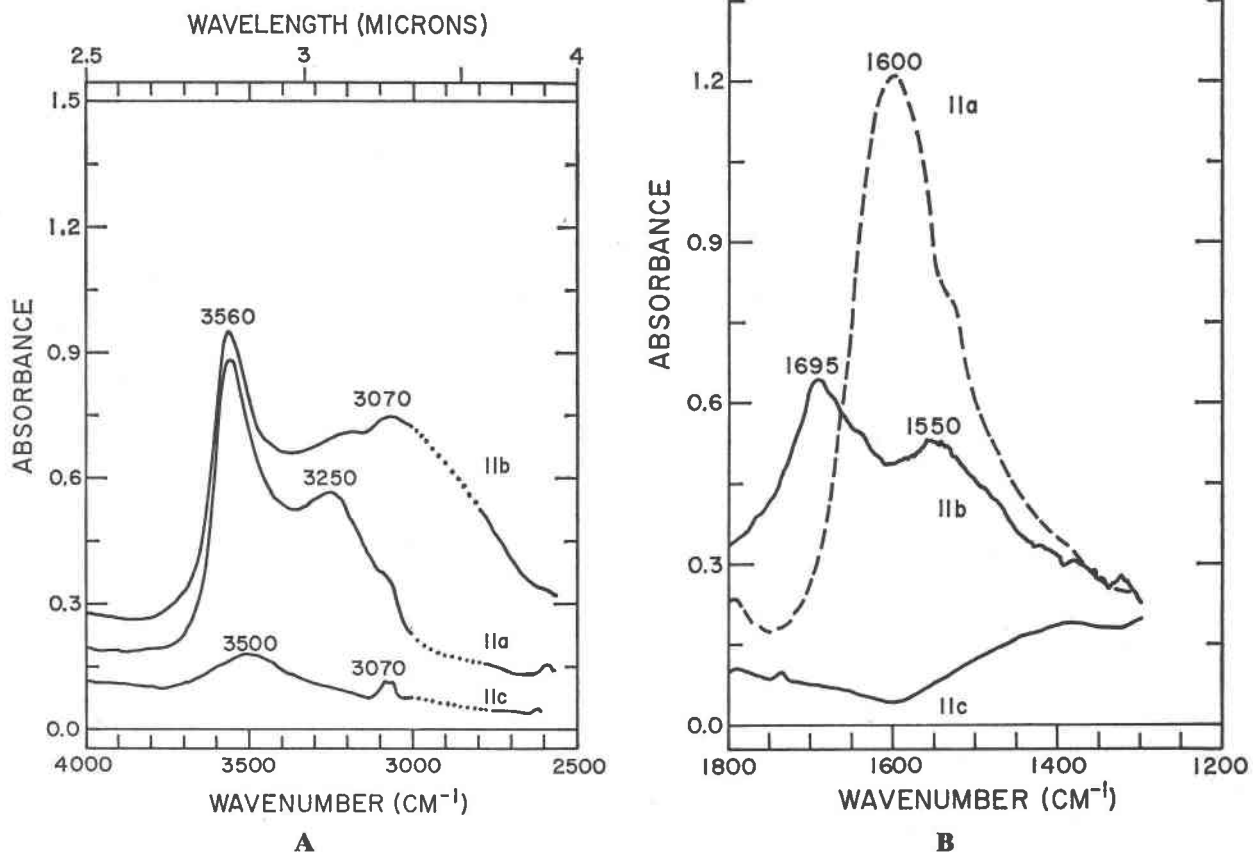

FIG. 4. Polarized infrared spectra of lawsonite with the electric vector oriented parallel to the a , b , and c crystallographic axes of lawsonite. Regions partially obscured by the mounting medium are shown in dotted lines ($3000\text{--}2800\text{ cm}^{-1}$). A. ($4000\text{--}2500\text{ cm}^{-1}$): Crystal thickness $8\text{ }\mu\text{m}$; the a and b spectra have been displaced vertically 0.1 and 0.2 units respectively for clarity. B. ($1800\text{--}1300\text{ cm}^{-1}$): no vertical displacement; crystal thickness $40\text{ }\mu\text{m}$.

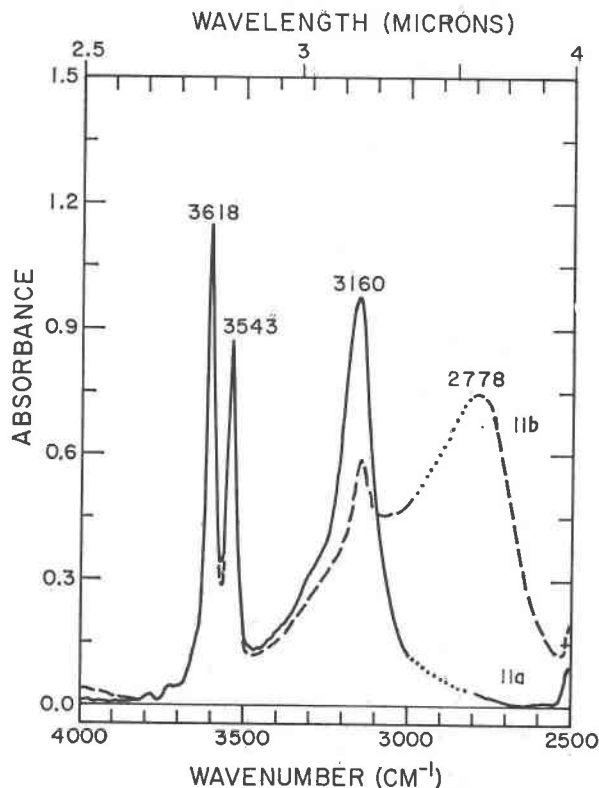

FIG. 5. Infrared spectrum of lawsonite near 78 K with the electric vector polarized parallel to *a* (solid line) and *b* (dashed line) crystallographic axes. Crystal thickness, 8 μm . Dotted where partially obscured by mounting medium.

water in the lawsonite, the normal modes of vibration of free H_2O can be compared with the modes predicted by more theoretical arguments based on the placement of an H_2O molecule in a crystal structure. Assuming that interactions between the water molecule and the other ions in the crystal structure are weak compared to the interactions between the hydrogen atoms and oxygen within the molecule, site group analysis can be applied to determine the number of infrared-active normal modes of vibration for the water molecules in the lawsonite structure. The model indicated by the data places the oxygen of water on a C_{2v} site and the hydrogen on an S_1 site within a crystal having D_{2h} symmetry. The factor group analysis (really site group analysis in this case) outlined by De Angelis, Newham, and White (1972) predicts two infrared-active modes absorbing parallel to *c*, three parallel to *b*, and three parallel to *a* (Table 1). The librational modes will absorb at the low frequency end of the spectrum leaving three modes, one parallel to *b* and two parallel to *a*, of completely internal

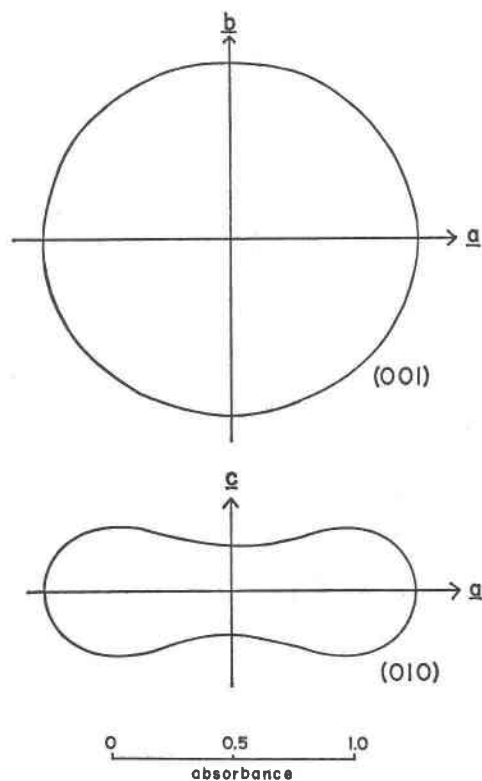

FIG. 6. Lawsonite absorption figure for a crystal 10 μm thick and at an energy of 3560 cm^{-1} projected on (001) and (010). Absolute absorbance is the length of the vector from the origin to the figure; the orientation of the vector represents the orientation of the electric vector with respect to the crystallographic axes of lawsonite.

vibrations. This is exactly what is seen in the data. Thus, for the orientation of H_2O in lawsonite proposed, the normal modes of vibration predicted by a free H_2O model are consistent with the modes of vibration predicted by the more involved site group analysis.

TABLE 1. Invariance Conditions for H_2O in Lawsonite

D_{2h}	E	$C_2(c)$	$C_2(b)$	$C_2(a)$	i	$\sigma(ab)$	$\sigma(ac)$	$\sigma(bc)$
2 O'_s on C_{2v}	E 2	- 0	C_2 2	- 0	- 0	$\sigma(\frac{ab}{2})$	- 0	$\sigma(\frac{bc}{2})$
4 H'_s on S_1	E 4	- 0	- 0	- 0	- 0	σ 4	- 0	- 0
ω_p	6	0	2	0	0	6	0	2
χ_p	18	0	-2	0	0	6	0	2
IR active modes: $2B_{1u}(\parallel c) + 3B_{2u}(\parallel b) + 3B_{3u}(\parallel a)$								

Discussion

The crystal structure of lawsonite projected on (001) with the hydrogen atoms positioned is shown in Figure 7. The absolute coordinates of the hydrogen atoms cannot be accurately determined from the infrared data, but all hydrogen-oxygen bonds lie in planes parallel to (001).

The infrared data show that the plane of the water molecule lies parallel to (001) and that the axis of the molecule is parallel to the a axis of lawsonite, but two possibilities remain for the positioning of the molecule within the structure. The molecule can either point toward or away from the Si-O-Si bridging oxygen in the (001) projection (Figure 7). The orientation shown in Figure 7 is chosen such that the interactions between the protons of the water molecule and the hydroxide ion are minimized. The final configuration shown in Figure 7 satisfies the space group requirements for lawsonite.

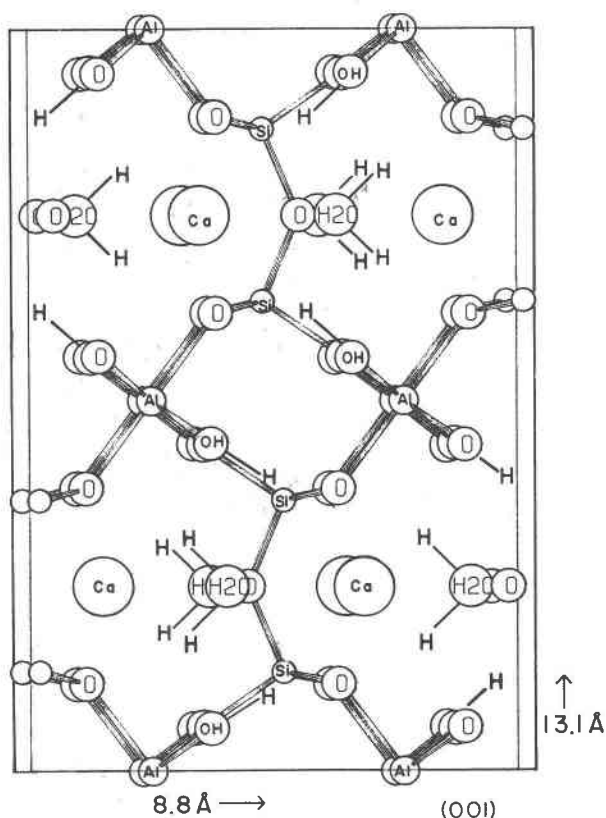

FIG. 7. The (001) projection of the lawsonite structure with the hydrogen atoms positioned according to the proposed structural model.

Summary

Infrared spectra of lawsonite indicate that the water molecules and OH groups are oriented within the (001) plane. A structural model has been presented which accounts for the orientation of the hydrogen-oxygen bonds within the crystal and agrees with qualitative predictions made from symmetry considerations regarding the bond orientation. It has also been shown that the relative energies of absorption for the symmetric and antisymmetric stretching modes of water are not unique and should be used with caution when assigning bands.

References

- ARKHIPENKO, D. K. (1960) Some singularities in the infrared spectra of mica, phlogophite-biotite sub-group. *Dokl. Mezhvuz. Nauch. Konf. Spektroskop. Spekr. Analizu, Tomsk. Univ.*, 81-82.
- BERAN, A. (1971a) Messung des Ultrarot-Pleochroismus von Mineralen. XII. Der Pleochroismus der OH-Streckfrequenz in Disthen. *Tschermaks Mineral. Petrogr. Mitt.* **16**, 129-134.
- (1971b) Messung des Ultrarot-Pleochroismus von Mineralen. XIII. Der Pleochroismus der OH-Streckfrequenz in Axinit. *Tschermaks Mineral. Petrogr. Mitt.* **16**, 281-286.
- BURNS, ROGER G., AND ANTONY D. LAW (1970) Hydroxyl stretching frequencies in the infrared spectra of anthophyllites and gedrites. *Nature*, **226**, 73-75.
- DAVIS, GREGORY A., AND A. PABST (1960) Lawsonite and pumpellyite in glaucophane schist, North Berkeley Hills, California, with notes on the x-ray crystallography of lawsonite. *Am. J. Sci.* **258**, 689-704.
- DEANGELIS, BERNARDO A., ROBERT E. NEWNHAM, AND WILLIAM B. WHITE (1972) Factor group analysis of the vibrational spectra of crystals: a review and consolidation. *Am. Mineral.* **57**, 255-268.
- GOSSNER, B., AND F. MUSSGNUNG (1931) Röntgenographische Untersuchung Prehnit und Lawsonit. *Centr. Mineral. Abt. A*, 419.
- HAAS, C., AND D. F. HORNIG (1960) Inter- and intramolecular potentials and the spectrum of ice. *J. Chem. Phys.* **32**, 1763-1769.
- HAAS, M., AND G. B. B. M. SUTHERLAND (1956) The infrared spectrum and crystal structure of gypsum. *Proc. Roy. Soc. (London)*, **A236**, 427-445.
- HORNIG, D. F., H. F. WHITE, AND F. P. REDING (1958) The infrared spectrum of crystalline H₂O, D₂O, and HDO. *Spectrochim. Acta*, **12**, 338-349.
- LAZAREV, A. N. (1972) *Vibrational Spectra and Structure of Silicates*. Consultants Bureau, New York. 302 p.
- LYON, R. J. P. (1967) Infrared absorption spectroscopy. In, J. Zussman, Ed., *Physical Methods in Determinative Mineralogy*. Academic Press, London, p. 371-403.
- MASON, BRIAN, AND L. G. BERRY (1968) *Elements of Mineralogy*. W. H. Freeman and Company, San Francisco, 550 p.

- MOENKE, HORST (1962) *Mineralspektren*. Akademie-Verlag, Berlin, 41 p.
- NAKAMOTO, KAZUO (1963) *Infrared Spectra of Inorganic and Coordination Compounds*. John Wiley and Sons, Inc., New York, 328 p.
- PABST, A. (1959) False symmetry, the Templeton effect, in lawsonite. *Z. Kristallogr.* **112**, 53–59.
- (1961) Supplementary note on "False symmetry, the Templeton effect, in lawsonite." *Z. Kristallogr.* **115**, 307–309.
- PISTORIUS, CARL W. F. T. (1961) Lattice constants of synthetic lawsonite. *Am. Mineral.* **46**, 982–985.
- ROUXHET, PAUL G. (1970) Hydroxyl stretching bands in micas: a quantitative interpretation. *Clay Mineral.* **8**, 375.
- RUMINOVA, I. M., AND N. V. BELOV (1960) False symmetry of lawsonite. *Kristallografiya*, **5**, 215–217. [transl. *Sov. Phys. Crystallogr.*, **5**, 199–201 (1960)].
- , AND T. I. SKIPETROVA (1959) The crystal structure of lawsonite. *Dokl. Akad. Nauk SSSR*, **124**, 324–327. [transl. *Sov. Phys. Dokl.*, **4**, 20–23 (1959)].
- RÜTSTEIN, MARTIN S., AND WILLIAM B. WHITE (1971) Vibrational spectra of high-calcium pyroxenes and pyroxenoids. *Am. Mineral.* **56**, 877–887.
- SEKI, YÔTARO (1957) Lawsonite from the eastern part of the Kantô Mountainland. *Sci. Rep. Saitama Univ., Series B*, **2**, 363–373.
- TILLMANN, E., AND J. ZEMANN (1965) Messung des Ultrarot-Pleochroismus von Mineralen. I. Der Pleochroismus der OH-Streckfrequenz in Azurit. *Neues Jahrb. Mineral. Monatsh.*, 228–231.
- VEDDER, W. (1964) Correlations between infrared spectrum and chemical composition of mica. *Am. Mineral.* **49**, 736–768.
- WHITE, WILLIAM B. (1971) Infrared characterization of water and hydroxyl ion in the basic magnesium carbonate minerals. *Am. Mineral.* **56**, 46–53.
- WICKMAN, FRANS E. (1947) The crystal structure of lawsonite, $\text{CaAl}_2(\text{Si}_2\text{O}_7)(\text{OH})_2 \cdot \text{H}_2\text{O}$. *Arkiv Kemi Mineral. Geol.* **25A**, 1–7.

Manuscript received, December 26, 1973; accepted for publication, February 26, 1974.