

A DEVICE FOR MEASURING THE EXTINCTION ANGLE

HIDEO INUZUKA,

*Research Laboratory, Matsuda Division,
Tokyo Shibaura Electric Co.*

The present tendency to obtain more accurate data in petrographic studies has led to a number of methods that give quantitative results.

The apparatus described here enables one to determine extinction angles of crystals in thin sections more accurately than by other methods formerly applied. Moreover, it has the advantage of being free from personal error.

It is hoped that by using the apparatus described below more quantitative petrographic work will be done.

THE APPARATUS

The first step in the construction of the extinction angle apparatus was the use of a cesium photoelectric cell and a galvanometer. The original apparatus, consisting of a photoelectric cell and galvanometer did not show sufficient sensitivity.

Our recent apparatus has a single stage amplifier to obtain good sensitivity, so that a small crystal, less than 1 mm., is easily measured, if there is no other crystal in the microscope field.

Sensitivities are recorded in three stages—high, medium, and low. At the same time a single stage amplifier eliminates the inconvenience of using a galvanometer, lamp and scale.

The entire apparatus is divided into three parts: a light receiving chamber including a photoelectric cell, an amplifying tube with high resistance, battery box and micro-ammeter.

The light receiving chamber, which is easily attached directly to the microscope tube, is connected to the battery box with a flexible cable, as is also the micro-ammeter.

Details for the electrical connections are shown in the following diagram. They are connected so as to eliminate the dark current of a vacuum tube.

DIRECTIONS FOR USE

(1) A crystal to be measured must be placed at the center of the microscope field, and then observed whether the crystal is large enough to cover the microscope field.

If the crystal is not large enough, a more powerful objective lens must be employed. The direction of a cleavage trace or the crystal edge must be determined on the microscope stage.

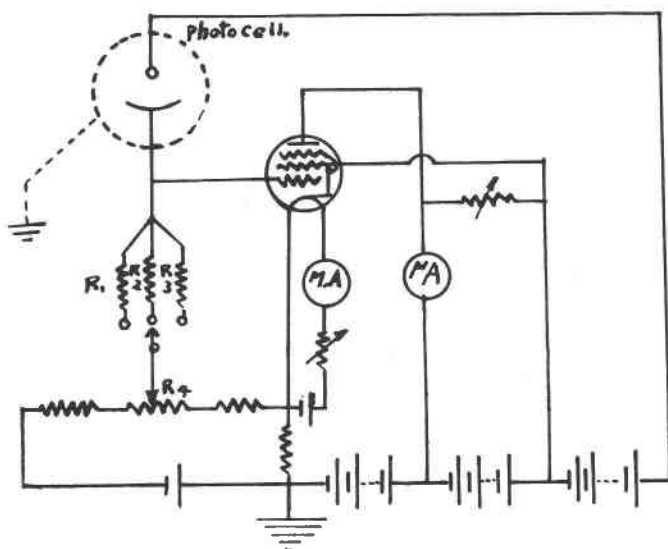

FIG. 1. R_1 , R_2 , R_3 are high resistances 1000Ω , 500Ω , and 100Ω each. R_4 acts as zero adjustable resistance.

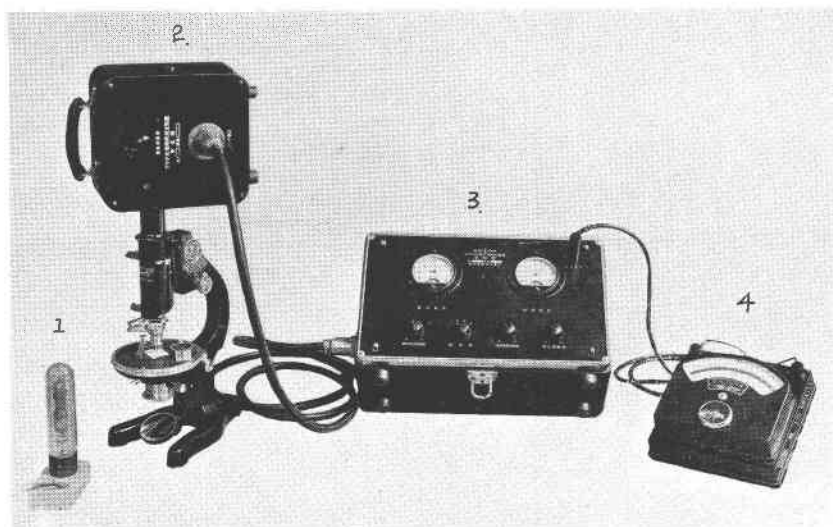

FIG. 2. Photograph shows the apparatus in position for measuring the extinction angle.
 (1) Na-lamp as a light source.
 (2) Microscope and light receiving chamber.
 (3) Battery box to which milli-ammeter and rheostats are connected.
 (4) Micro-ammeter.

(2) Attach the light receiving chamber, in place of the eye-piece. Of course suitable sensitivities are selected in each case.

(3) Turn the stage, and determine the extinction angle between the minimum amplitude of the micro-ammeter and the direction of the

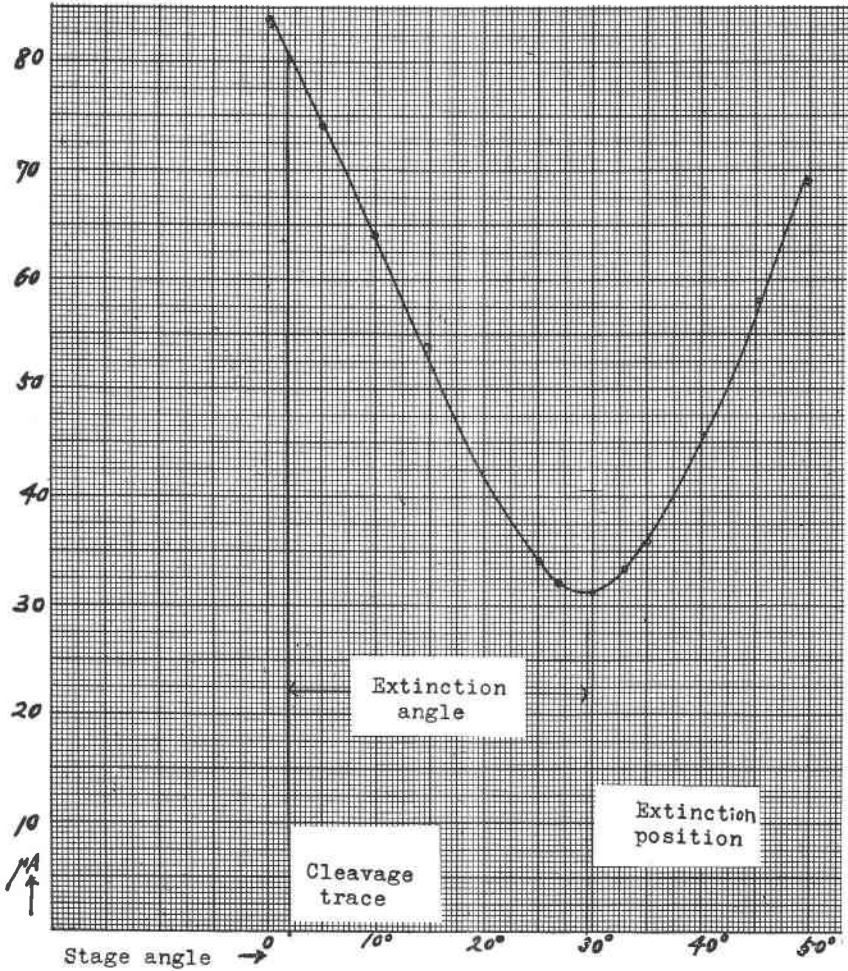

FIG. 3

cleavage trace, or draw a diagram of the stage angle and micro-ammeter amplitude.

Figure 3 shows the result of extinction angle measurements of diopside with a Na-lamp.

The extinction angle can be measured within an error of 30 minutes. This apparatus is also used in saccharimetry.